



MANDO T211

mandrel with draw bolt

Mandrel MANDO T211

Ideal clamping of inner diameters:

- Vibration dampening and enormous clamping force
- Large stroke makes automatic loading easy
- Pull-back clamping

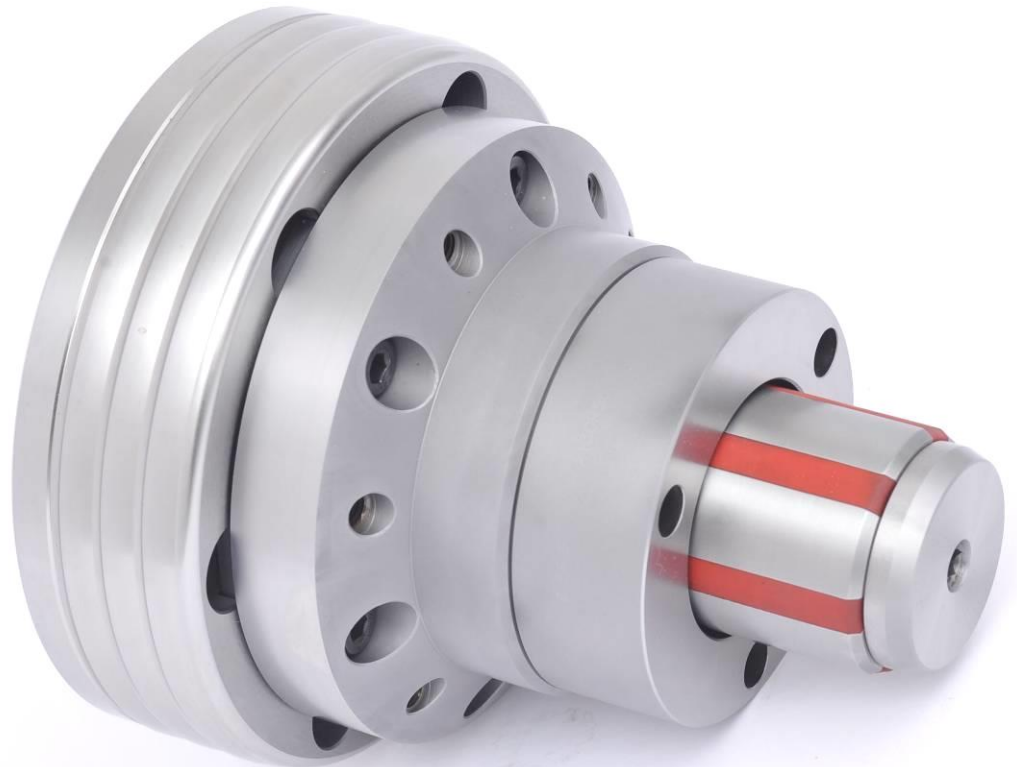

Mandrel MANDO T211

Details:

- Prepared for air sensor control

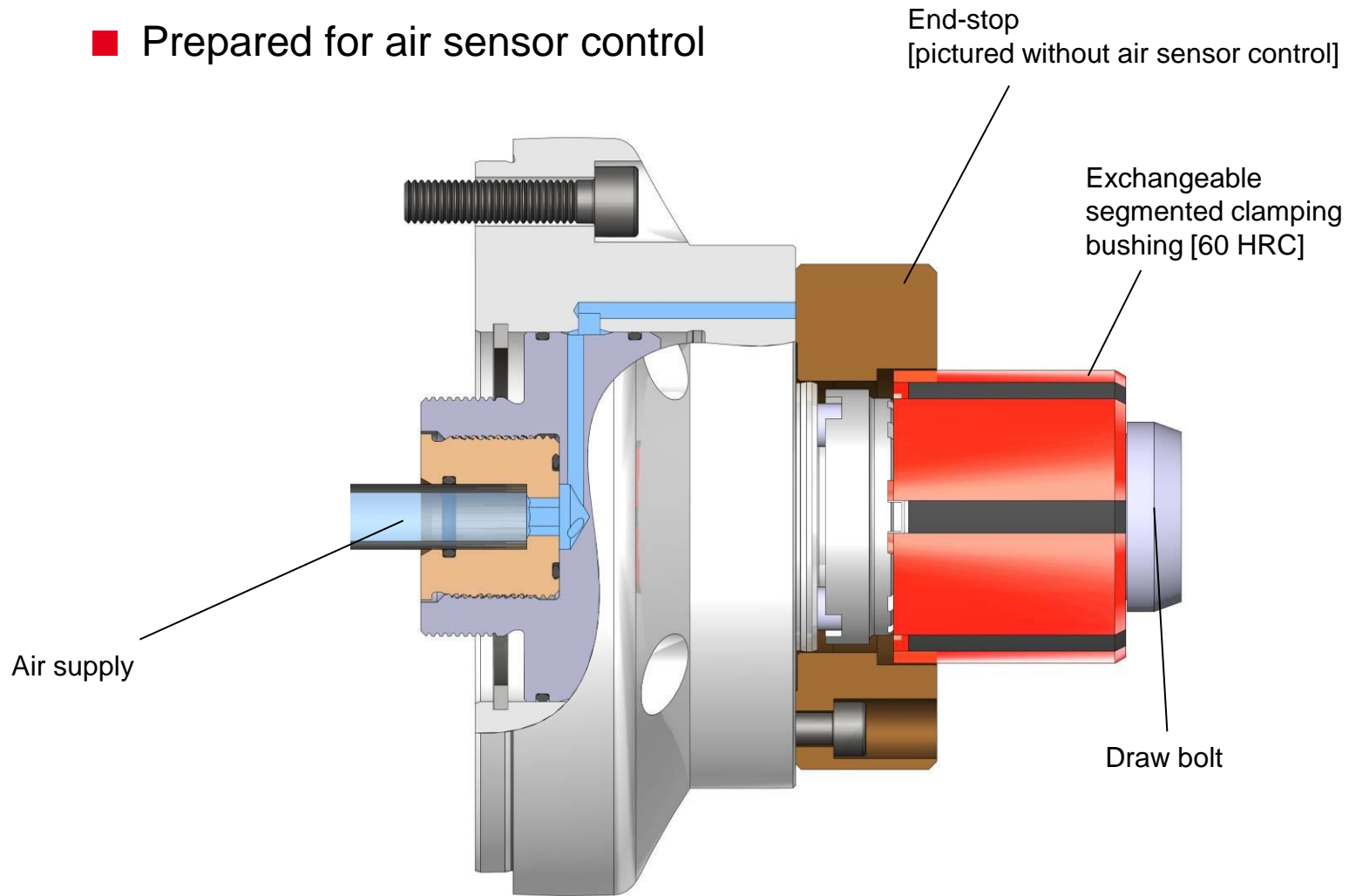

Mandrel MANDO T211

Easy change-over:

- In less than 2 minutes...

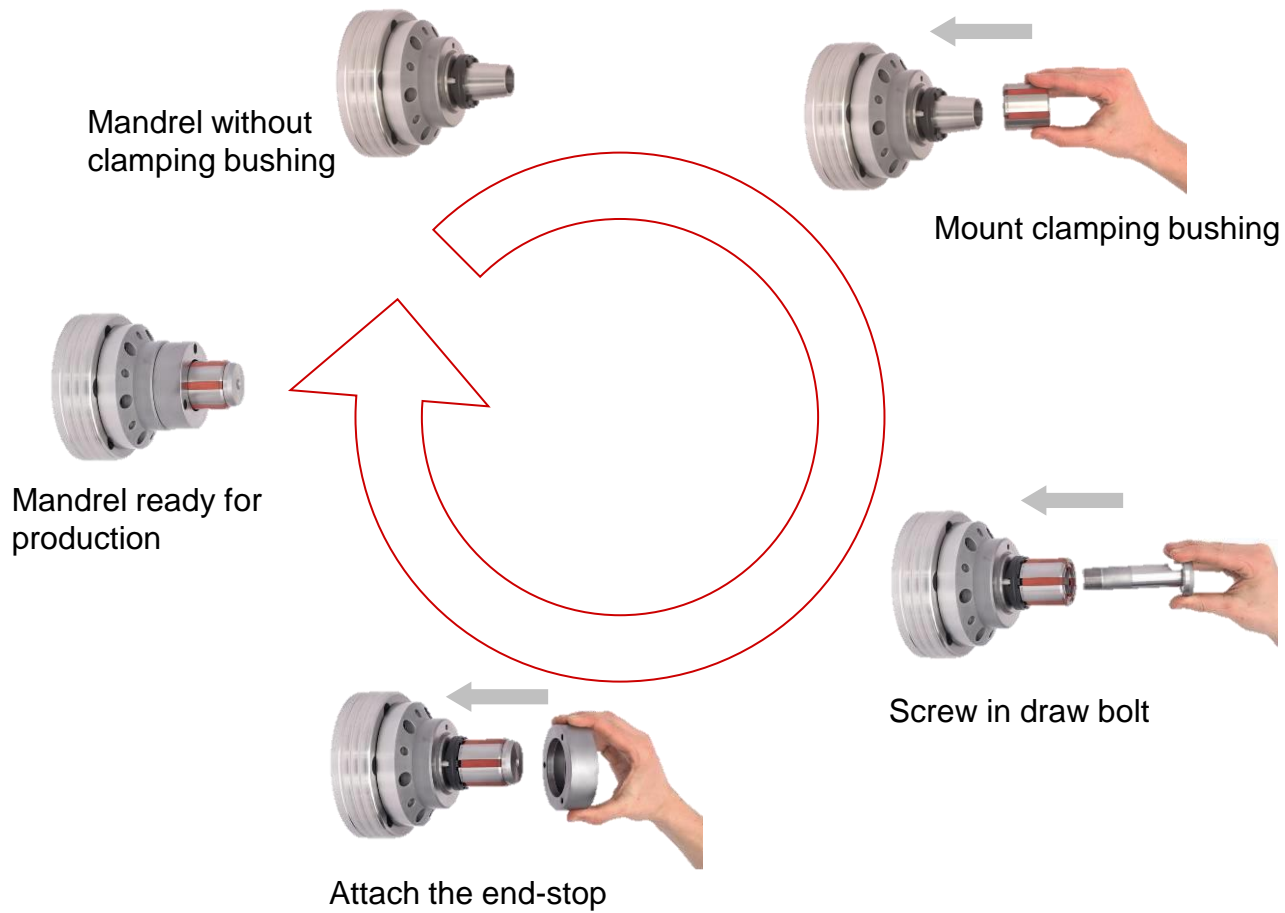

Accessory

End-stop blanks:

- »Soft« [45 HRC] for customization

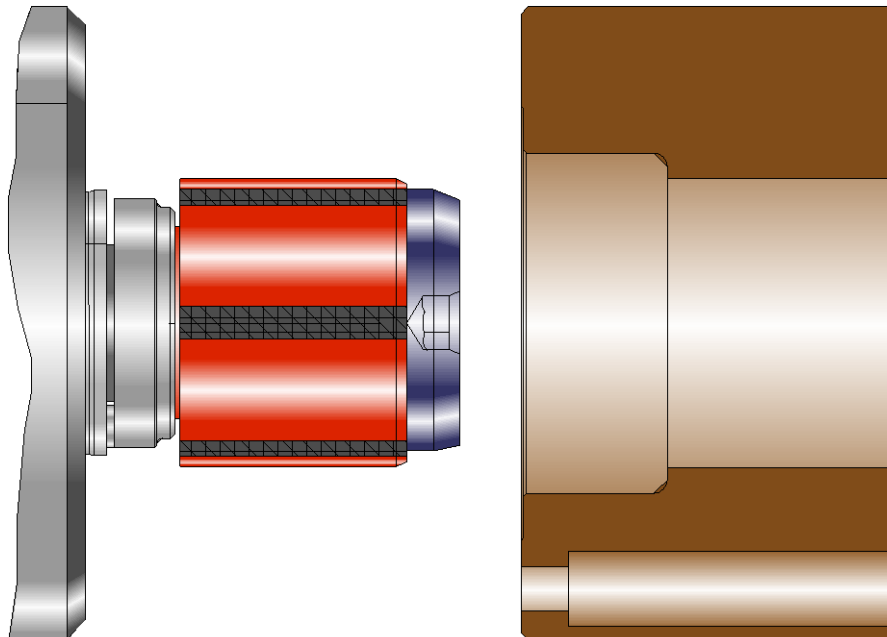
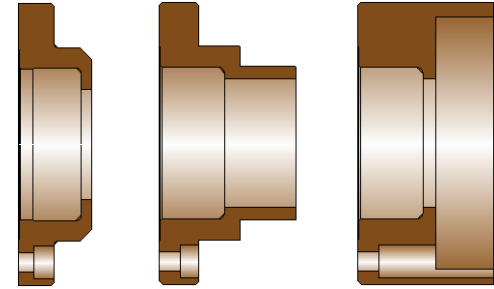

Accessory

»Soft« segmented clamping bushing:

- SAD bushing [50 HRC] for customization
- React quickly on custom sizes
- Concentricity = machine accuracy

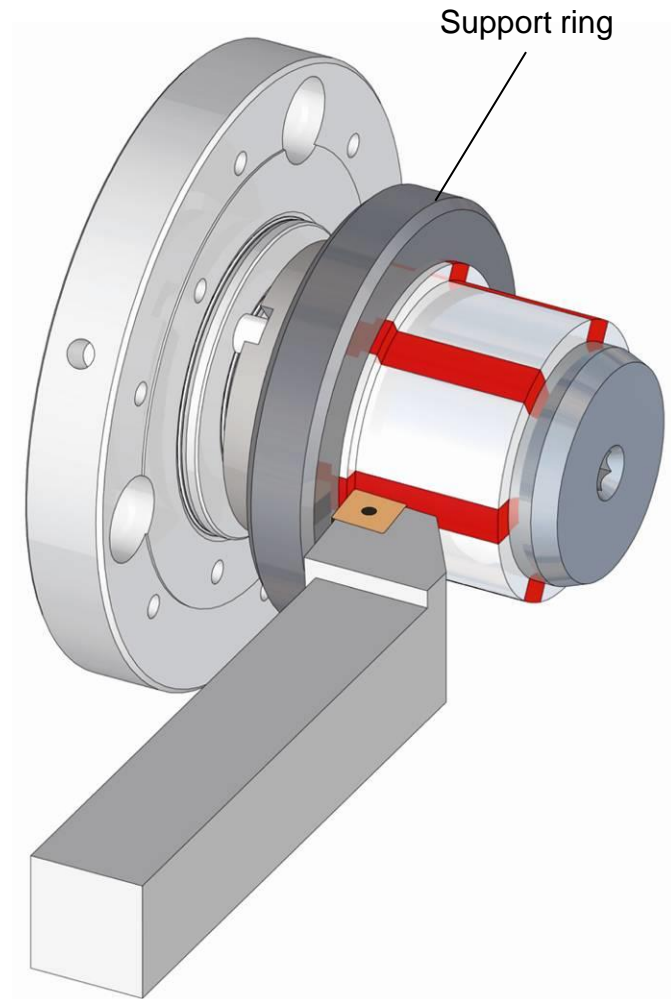

Mandrel MANDO T211

Full flexibility – also for stationary applications:



MANDO T211 mandrel
on ms dock
[manual actuation]



MANDO T211 mandrel
on hs dock
[hydraulic actuation]

And what can we do for you?