



MANDO G211

mandrel with draw bolt

mandrel MANDO G211

Optimal I.D. clamping by:

- Vibration dampening effect and enormous holding power
- Large clamping range for automatic loading
- Pull-back clamping
- Three end-stop levels
- Integrated flushing bore



mandrel MANDO G211

Details:

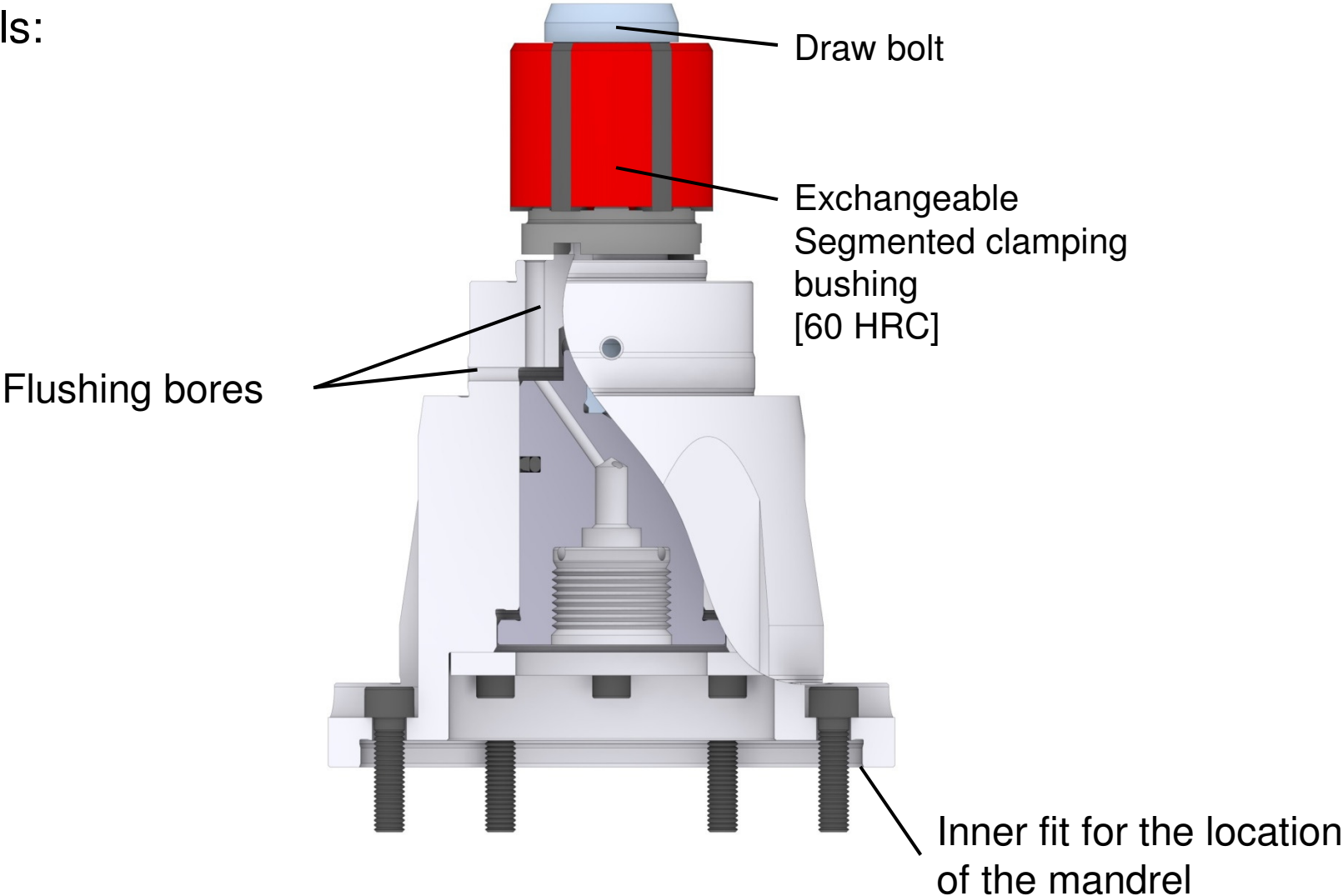

mandrel MANDO G211

Easy change-over:

■ in less than 2 minutes...

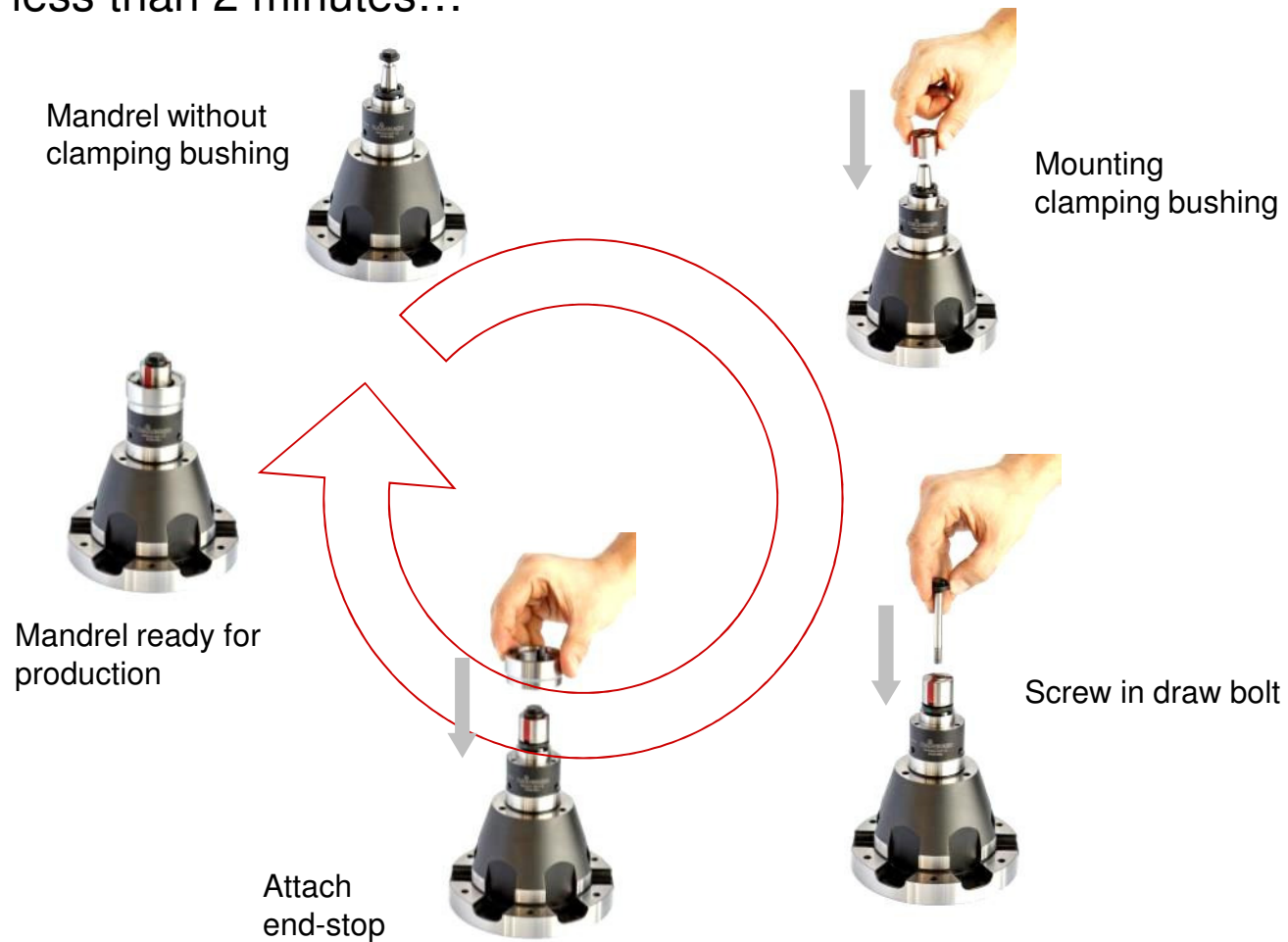

mandrel MANDO G211

Connection examples:

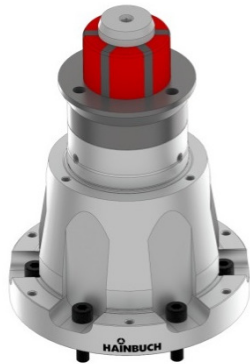

mandrel without
flange



mandrel with machine specific
connection



mandrel with quick
change-over system
mandoteX



mandrel with hs-dock

mandrel MANDO G211



www.hainbuch.com

And what we can do for you?

HAINBUCH