

# CENTREX duo

centering unit

# CENTREX duo centering system

## Features:

- Perfect for all positioning applications
- Repeat accuracy less than 3  $\mu\text{m}$  [.00012 in.]
- No tilting
- Resistant to contamination

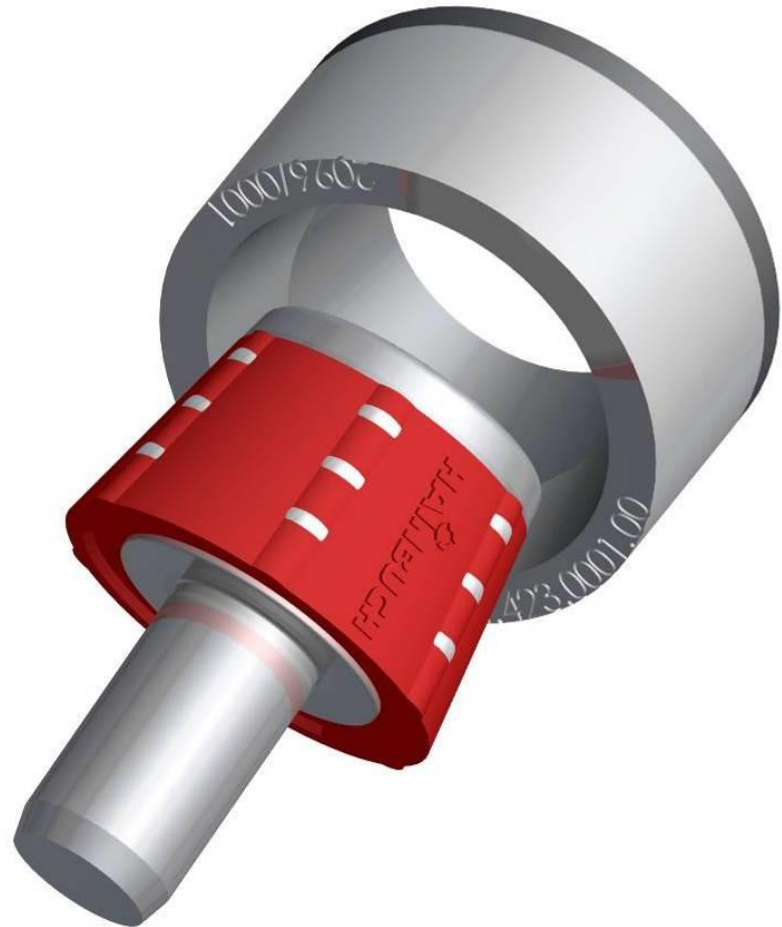

# Application

Used in various clamping devices:

- Here with the CENTREX pallet system



# Application

Used in various clamping devices:

- Special solution: Weight of clamping device about 1.3 tons

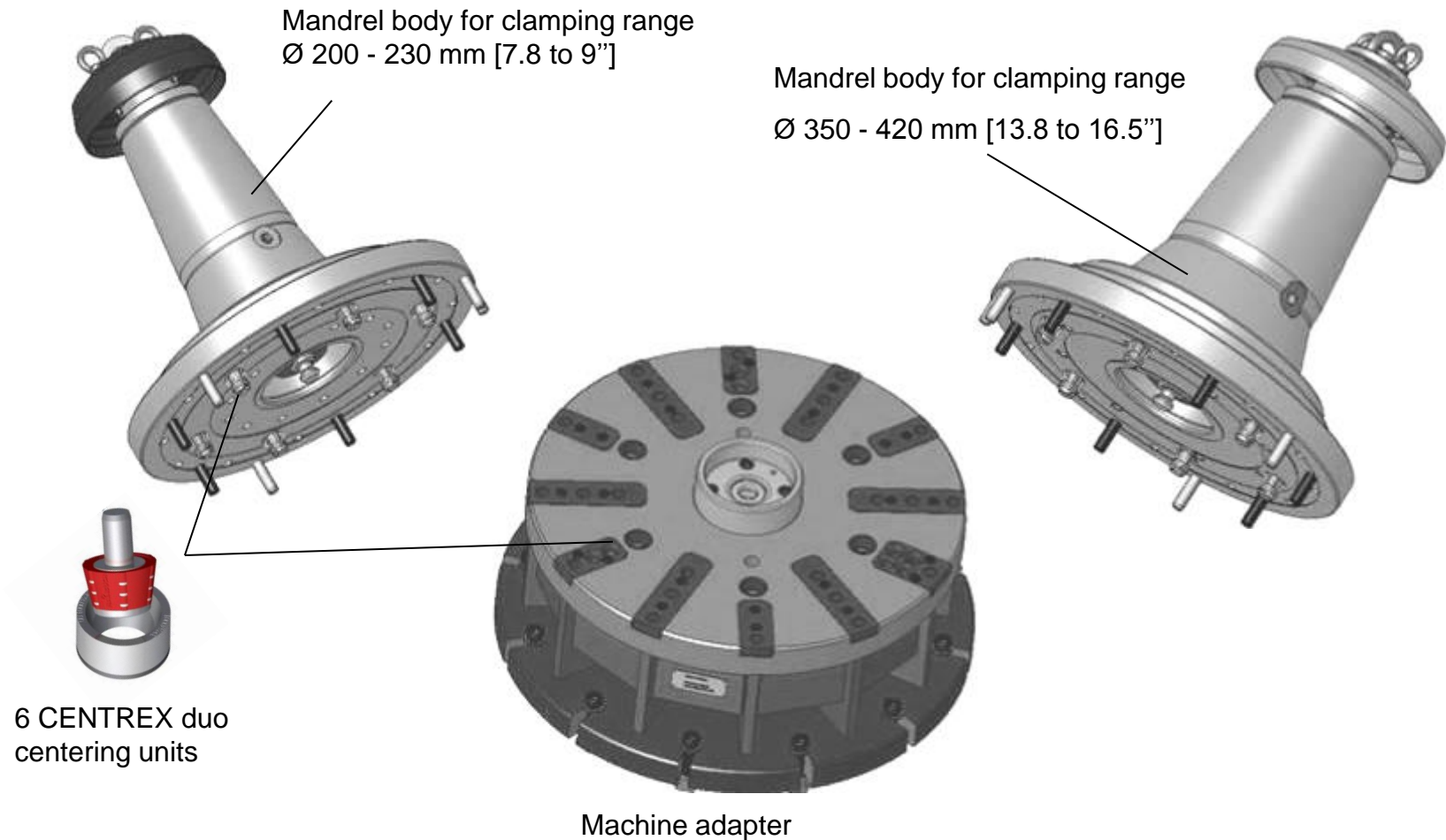

# Application

Another example: Pallet system for EDM:

- Exchangeable pallets for short set-up times

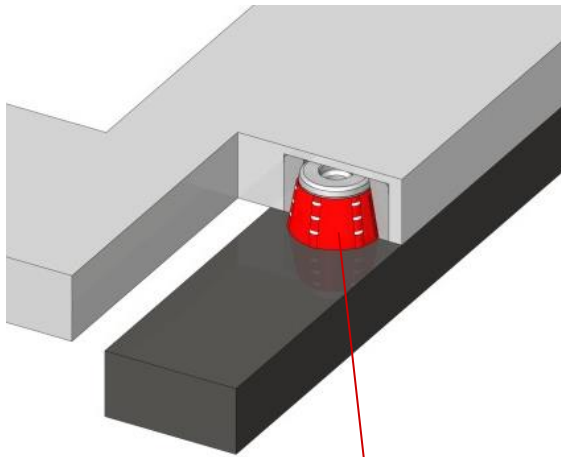

CENTREX duo centering unit  
[stainless variant]

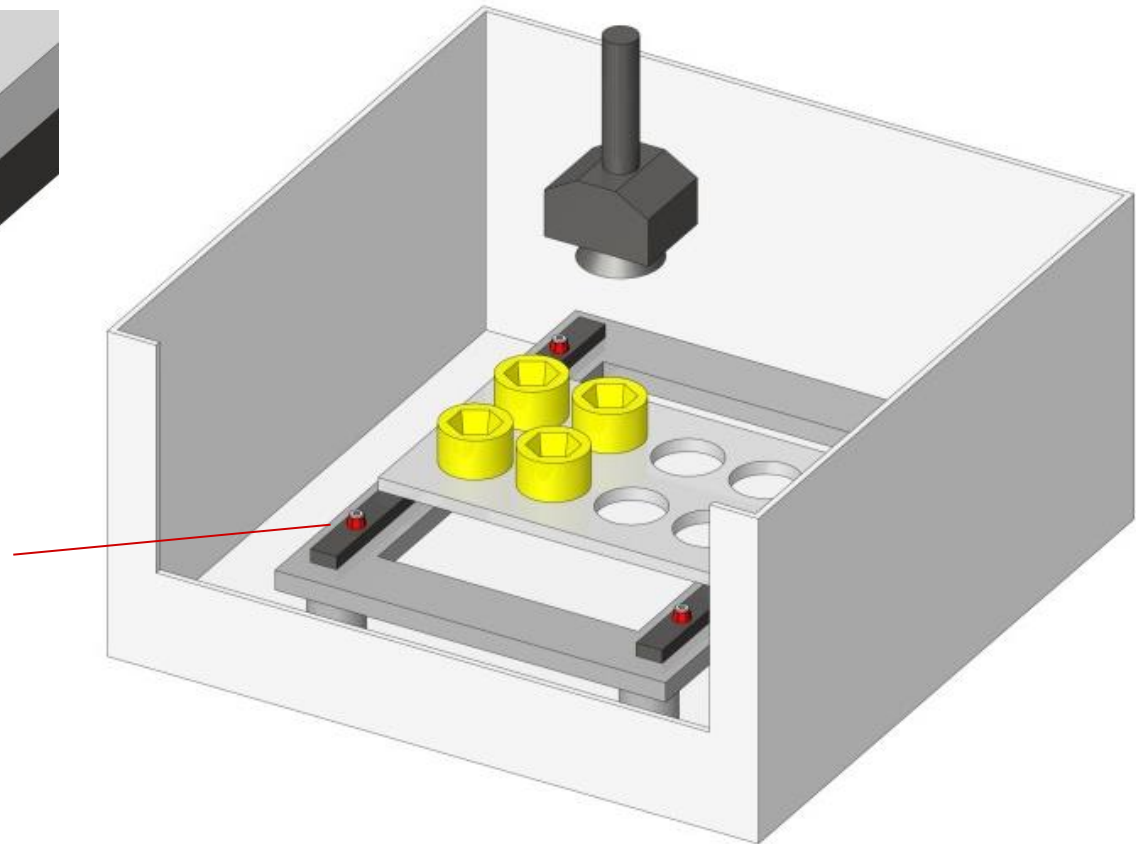

# Application

## Advantages:

- External change-over preparation while the machine is running
- Rapid pallet changes
- No aligning after change

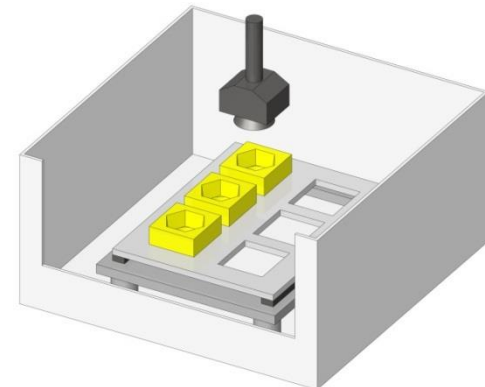
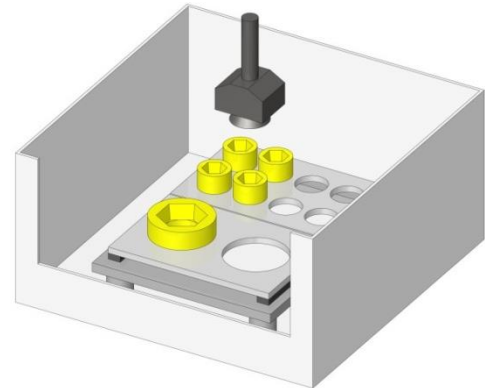
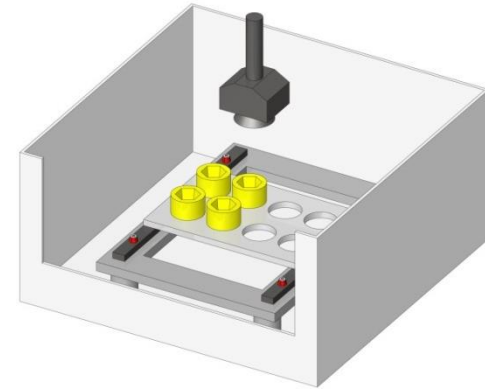

# Application

## Advantages:

- Diversified pallet design
- Unmanned operation due multi-clampings

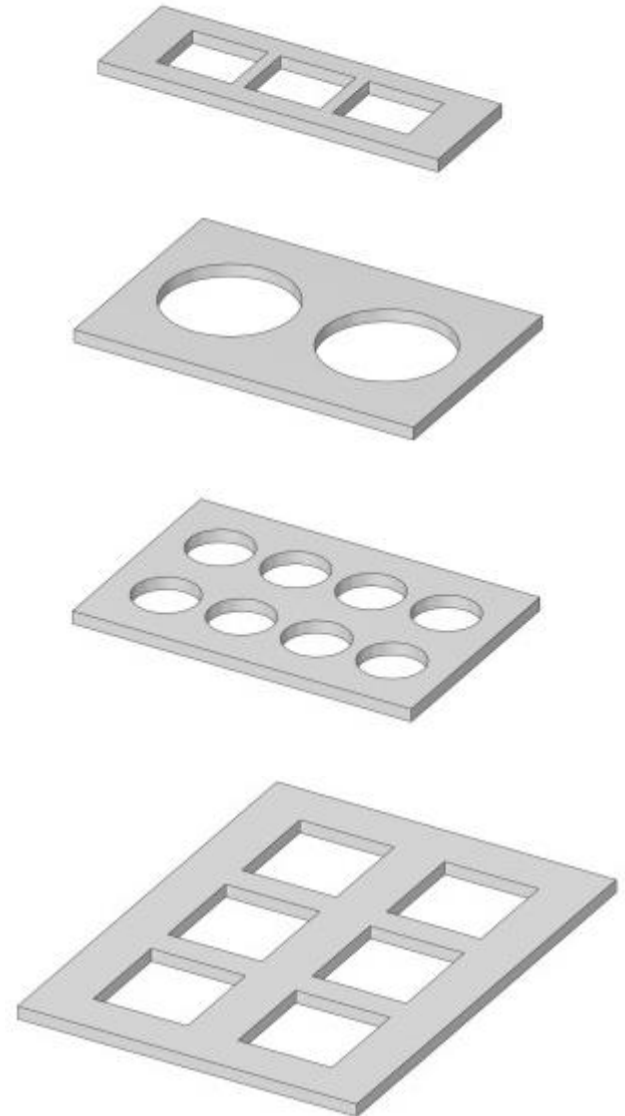
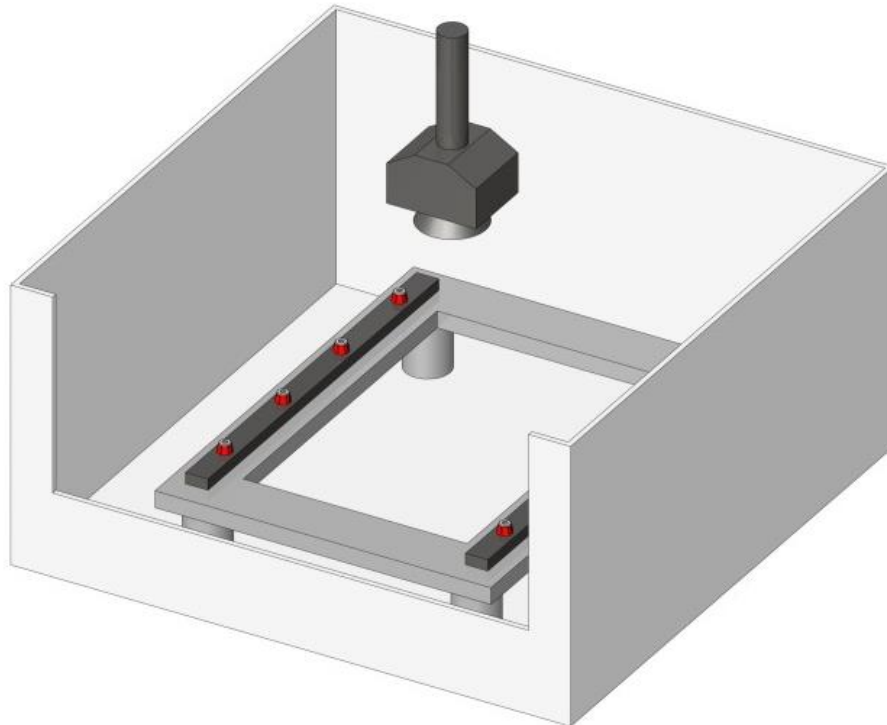

And what can we do for you?