

# Products & Services

## Versatile, Quick-Setup 5-Axis Clamping Vise Supports Five-Side Machining of Workpieces of Nearly Any Type

The innovative double-concentric Quadrok 5-axis clamping vise from Hainbuch GmbH Spannende Technik brings to the market a clamping system that can save users of machining centres the trouble of complex and expensive customized solutions. The Quadrok offers strengths in the area of five-side machining. It

can clamp workpieces of almost any type through a clamping repertoire that is essentially inexhaustible. Setup takes no more than 2 minutes.

Highlights of the practical all-around clamp include surrounding, four-side clamping; extremely shallow clamping; optimal material removal values through active pull-back; and a maximum acceptable workpiece size

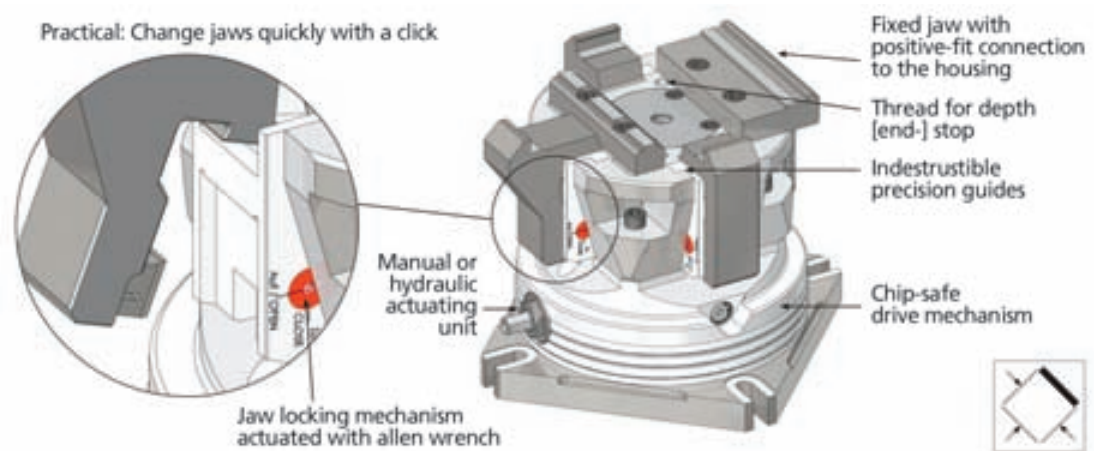

of 250 x 250 mm. It allows simple saw cuts to be machined with the same high level of performance as complex cast parts. The user can choose among five clamping functions: vise, concentric, double-vise, concentric-plus-vise, or double-concentric.

Quadrok clamps with total flexibility, from outside and from inside. Even mandrel or chuck clamping can be re-

alized with this 5-axis vise. Hainbuch has designed the device to enable users to complete machining jobs more rapidly, more flexibly and more cost-effectively and thus ensure customer satisfaction through greater delivery reliability.

**Hainbuch GmbH Spannende Technik**

MARBACH/NECKAR, GERMANY

[www.hainbuch.com](http://www.hainbuch.com)